

# S008 series

## Partial-turn gear operators

This series consists of 15 models varying from 42:1 to 3525:1 in terms of gear ratio and from 720NM to 150000NM in terms of torque.

The torque difference between every two adjacent models is small, helping to save a lot of costs customers when selecting a specific product.

It is suitable for use on 90° rotary butterfly valves, ball valves, and plug valves.

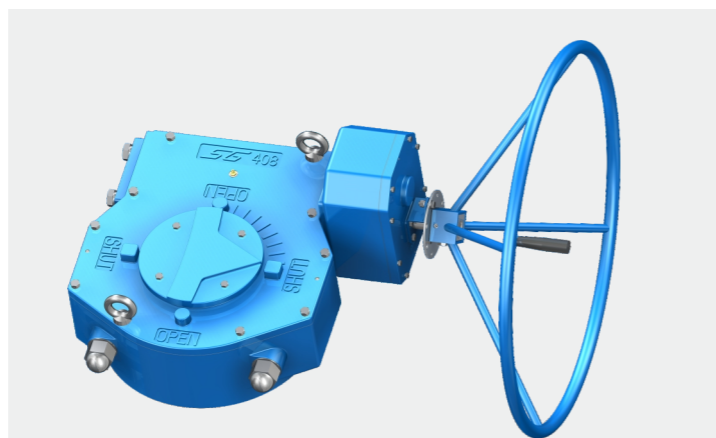

### Texture of material

| Part name                         | GB                          | ASTM/AWS       | BS          | ISO     |
|-----------------------------------|-----------------------------|----------------|-------------|---------|
| Hand wheel                        | Q235A                       | A570 Gr.A      | S235JR      | Fe 360A |
| Secondary reduction gearbox cover | QT450-10                    | 65-45-12       | 420/12      | 450-10  |
| Seal up                           | NBR                         |                |             |         |
| Input shaft                       | 45                          | 1045           | C45E 080M40 | SM45C   |
| Gear wheel                        | 45                          | 1045           | C45E 080M40 | SM45C   |
| Secondary reducer box             | QT450-10                    | 65-45-12       | 420/12      | 450-10  |
| Housing                           | QT450-10                    | 65-45-12       | 420/12      | 450-10  |
| Bearing                           | One-way thrust ball bearing |                |             |         |
| Worm                              | 45                          | 1045           | C45E 080M40 | SM45C   |
| Left end cover                    | QT450-10                    | 65-45-12       | 420/12      | 450-10  |
| Indieator                         | HT250                       | No.35<br>No.40 |             | 250     |
| Cover                             | QT450-10                    | 65-45-12       | 420/12      | 450-10  |
| Worm gear                         | QT500-7                     | 88-55-06       | 500/7       | 500-7   |

Note: Due to the company's policy of continuous improvement, Stard-Gears reserves the right to change specification details without prior notice.



### Instructions for Installation and Operation

Connect the bottom flange of the gear operator to the upper flange of the valve and slide the valve shaft into the hole on the worm gear. Tighten the flange bolt. The valve can be closed by turning the hand-wheel clockwise and opened by turning the hand-wheel counterclockwise. On the upper face of the gear operator, a position indicator and a position marking are mounted, through which the position of switch can be directly observed. The gear operator is also equipped with a mechanical limit screw, which can be adjusted and function to limit the position at the switch extreme position.

### Product Features

- 1. Ductile iron housing
- 2. Protected steel input shaft
- 3. 15 models up to 150000 Nm output
- 4. Rugged construction
- 5. Ductile iron worm gear
- 6. NBR sealing materials
- 7. Suitable for -20°C ~ 120°C working conditions
- 8. Stroke: 0 - 90° (± 5° adjustable)
- 9. Designed with a lock mechanism

### Customization

- 1. IP68 grade protection
- 2. Aluminum-bronze worm gear
- 3. Stainless steel input shaft
- 4. Limit switches
- 5. Interlock safety system

### S008 Performance Parameters

| Model | Ratio  | Rating input (Nm) | Rating output (Nm) | Efficiency(%) | M.A. (±10%) |
|-------|--------|-------------------|--------------------|---------------|-------------|
| S007  | 42:1   | 80                | 720                | 21            | 9.0         |
| S008  | 50:1   | 110               | 1200               | 22            | 10.9        |
| S108  | 72:1   | 130               | 2000               | 21            | 15.4        |
| S158  | 70:1   | 150               | 2500               | 24            | 16.7        |
| S208  | 68:1   | 210               | 3300               | 23            | 15.7        |
| S218  | 78:1   | 206               | 4475               | 28            | 21.7        |
| S238  | 175:1  | 170               | 6250               | 21            | 36.8        |
| S308  | 275:1  | 150               | 9800               | 24            | 65.3        |
| S358  | 532:1  | 170               | 18000              | 20            | 105.9       |
| S408  | 700:1  | 190               | 32000              | 24            | 168.4       |
| S448  | 1233:1 | 165               | 42000              | 21            | 254.5       |
| S508  | 1254:1 | 190               | 60000              | 25            | 315.8       |
| S608  | 1855:1 | 190               | 80000              | 23            | 421.1       |
| S708  | 2292:1 | 190               | 100000             | 23            | 526.3       |
| S808  | 3525:1 | 190               | 150000             | 22            | 789.5       |

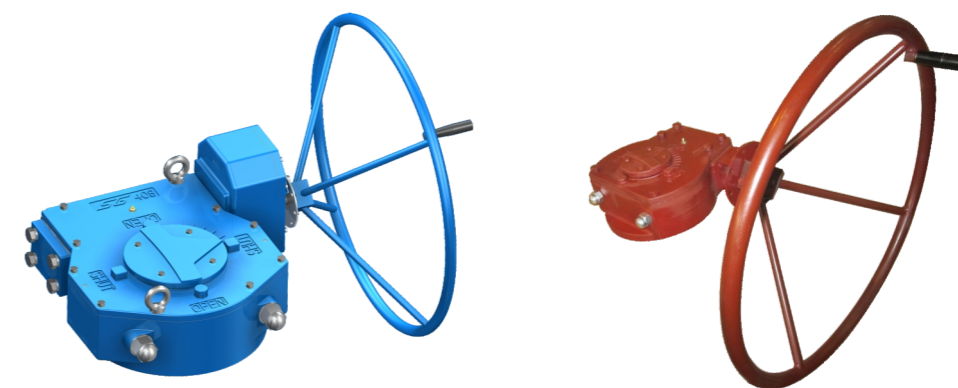

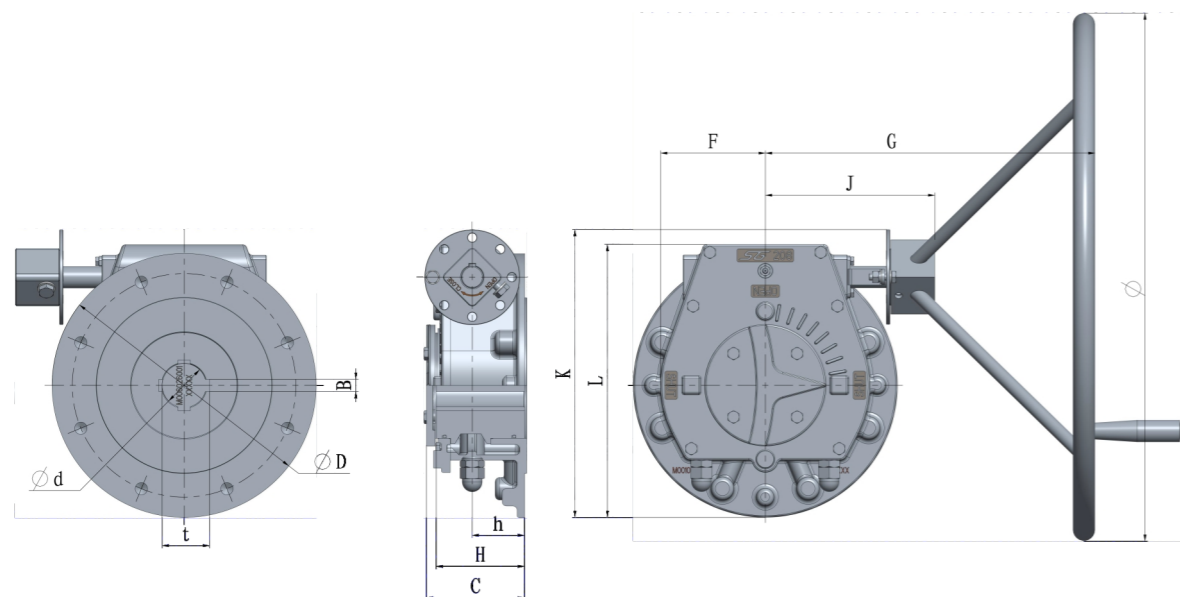

**S008 Series Single Stage Dimension Parameter Table**

| Model | ΦD   | Flange | dmax | B  | t    | h    | H     | C     | F    | G     | J     | K      | L      | Φ    |
|-------|------|--------|------|----|------|------|-------|-------|------|-------|-------|--------|--------|------|
| S007  | Φ150 | F10    | Φ38  | 10 | 41.3 | 39   | 82    | 91.5  | 78.8 | 241   | 164   | 198.5  | 176    | Φ465 |
|       | Φ150 | F12    | Φ38  | 10 | 41.3 | 39   | 82    | 91.5  | 78.8 | 241   | 164   | 198.5  | 176    | Φ465 |
| S008  | Φ150 | ☆F10   | Φ45  | 14 | 48.8 | 41.5 | 77.5  | 86.5  | 77.5 | 244   | 167   | 210    | 184    | Φ465 |
|       | Φ150 | F12    | Φ45  | 14 | 48.8 | 41.5 | 77.5  | 86.5  | 77.5 | 244   | 167   | 210    | 184    | Φ465 |
|       | Φ175 | F14    | Φ45  | 14 | 48.8 | 46.5 | 82.5  | 91.5  | 77.5 | 244   | 167   | 219    | 192.5  | Φ465 |
| S108  | Φ210 | F16    | Φ45  | 14 | 48.8 | 50.5 | 86.5  | 95.5  | 77.5 | 244   | 167   | 236.5  | 210    | Φ465 |
|       | Φ175 | F14    | Φ54  | 16 | 58.3 | 46   | 82    | 91    | 87.5 | 351   | 169   | 233    | 212    | Φ600 |
| S158  | Φ210 | ☆F12   | Φ60  | 18 | 64.4 | 51   | 100   | 109.5 | 115  | 379   | 197   | 275.5  | 262    | Φ600 |
|       | Φ210 | F14    | Φ60  | 18 | 64.4 | 51   | 100   | 109.5 | 115  | 379   | 197   | 275.5  | 262    | Φ600 |
| S208  | Φ210 | ☆F14   | Φ85  | 22 | 90.4 | 59.5 | 100.5 | 111.5 | 119  | 396.5 | 191.5 | 298    | 281    | Φ750 |
|       | Φ210 | F16    | Φ85  | 22 | 90.4 | 59.5 | 100.5 | 111.5 | 119  | 396.5 | 191.5 | 298    | 281    | Φ750 |
|       | Φ300 | F25    | Φ85  | 22 | 90.4 | 59.5 | 100.5 | 111.5 | 119  | 396.5 | 191.5 | 310    | 237    | Φ750 |
| S218  | Φ210 | ☆F14   | Φ85  | 22 | 90.4 | 59   | 100.5 | 115   | 135  | 410   | 205   | 312.75 | 296.75 | Φ750 |
|       | Φ300 | F25    | Φ85  | 22 | 90.4 | 59   | 100.5 | 115   | 135  | 410   | 205   | 339.75 | 323.75 | Φ750 |

Note: "☆" Unable to machine Convex/Concave positioning steps.

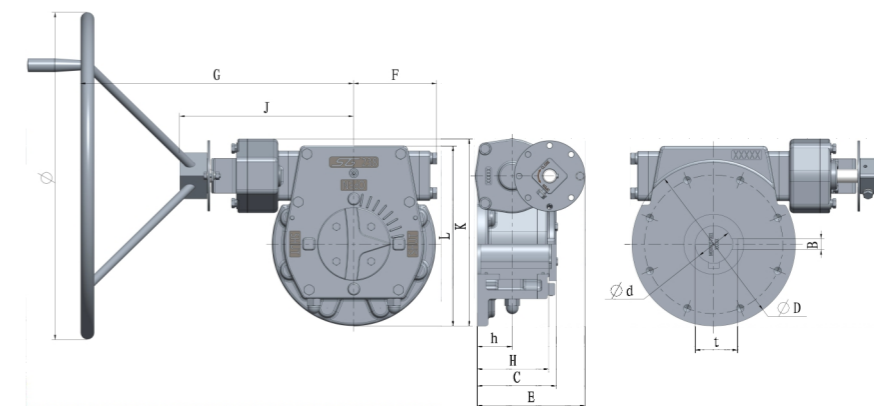

**S008 Series Multistage Dimension Parameter Table**

| Model | ΦD   | Flange | dmax | B  | t     | h    | H   | C   | E     | F      | G   | J   | K     | L     | Φ    |
|-------|------|--------|------|----|-------|------|-----|-----|-------|--------|-----|-----|-------|-------|------|
| S238  | Φ300 | ☆F14   | Φ83  | 22 | 88.4  | 61   | 128 | 142 | 194.5 | 152.4  | 501 | 319 | 330   | 343   | Φ600 |
|       |      | F16    |      |    |       |      |     |     |       |        |     |     |       |       |      |
|       |      | F25    |      |    |       |      |     |     |       |        |     |     |       |       |      |
| S308  | Φ340 | ☆F16   | Φ100 | 28 | 106.4 | 74.5 | 151 | 165 | 229.5 | 173.25 | 544 | 339 | 413.5 | 391.5 | Φ750 |
|       |      | F25    |      |    |       |      |     |     |       |        |     |     |       |       |      |
|       |      | F30    |      |    |       |      |     |     |       |        |     |     |       |       |      |

Note: "☆" Unable to machine Convex/Concave positioning steps.

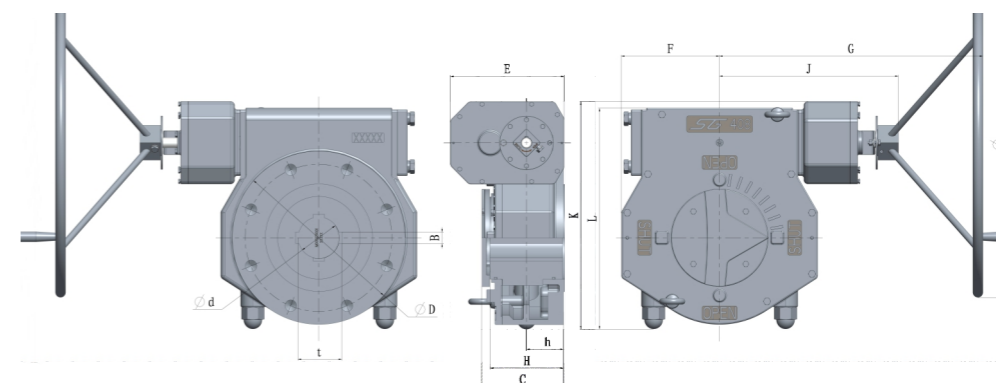

**S008 Series Multistage Dimension Parameter Table**

| Model | ΦD   | Flange | dmax | B  | t     | h     | H     | C     | E   | F      | G     | J     | K     | L     | Φ    |
|-------|------|--------|------|----|-------|-------|-------|-------|-----|--------|-------|-------|-------|-------|------|
| S358  | Φ350 | F25    | Φ120 | 32 | 127.4 | 88    | 180   | 192   | 262 | 192.8  | 602.3 | 396.3 | 442.3 | 424   | Φ750 |
|       | Φ350 | F30    | Φ120 | 32 | 127.4 | 88    | 180   | 192   | 262 | 192.8  | 602.3 | 396.3 | 442.3 | 424   | Φ750 |
| S408  | Φ415 | ☆F25   | Φ150 | 36 | 158.4 | 90    | 178   | 198   | 276 | 238    | 638   | 433   | 551   | 535   | Φ750 |
|       | Φ415 | F30    | Φ150 | 36 | 158.4 | 90    | 178   | 198   | 276 | 238    | 638   | 433   | 551   | 535   | Φ750 |
|       | Φ475 | F40    | Φ150 | 36 | 158.4 | 119.5 | 207.5 | 227.5 | 276 | 232.4  | 638   | 433   | 567.5 | 551.5 | Φ750 |
| S448  | Φ415 | F30    | Φ150 | 36 | 158.4 | 84    | 178   | 192   | 353 | 239    | 671   | 466   | 575   | 537   | Φ750 |
|       | Φ415 | F35    | Φ150 | 36 | 158.4 | 84    | 178   | 192   | 353 | 239    | 671   | 466   | 575   | 537   | Φ750 |
| S508  | Φ475 | ☆F35   | Φ220 | 50 | 231.4 | 120.5 | 241.5 | 255.5 | 369 | 300.3  | 718.8 | 513.8 | 675.7 | 653.7 | Φ750 |
|       | Φ475 | F40    | Φ220 | 50 | 231.4 | 120.5 | 241.5 | 255.5 | 369 | 300.3  | 718.8 | 513.8 | 675.7 | 653.7 | Φ750 |
| S608  | Φ560 | ☆F40   | Φ240 | 56 | 252.4 | 135   | 271   | 286   | 520 | 345.55 | 788   | 583   | 813.7 | 758.7 | Φ750 |
|       | Φ560 | F48    | Φ240 | 56 | 252.4 | 135   | 271   | 286   | 520 | 345.55 | 788   | 583   | 813.7 | 758.7 | Φ750 |
| S708  | Φ560 | ☆F40   | Φ240 | 56 | 252.4 | 140   | 281   | 296   | 520 | 395.8  | 839.3 | 634.3 | 902.7 | 853.7 | Φ750 |
|       | Φ560 | F48    | Φ240 | 56 | 252.4 | 140   | 281   | 296   | 520 | 395.8  | 839.3 | 634.3 | 902.7 | 853.7 | Φ750 |
| S808  | Φ686 | ☆F48   | Φ280 | 63 | 292.4 | 143   | 313   | 331   | 393 | 470    | 927   | 722   | 1074  | 1042  | Φ750 |
|       | Φ686 | F60    | Φ280 | 63 | 292.4 | 143   | 313   | 331   | 393 | 470    | 927   | 722   | 1074  | 1042  | Φ750 |

Note: "☆" Unable to machine Convex/Concave positioning steps.